

suffel

# COMBiLiFT

LIFTING INNOVATION

## COMBi-RT

The Combi-RT forklift is designed for use on rough terrain, catering to your poultry and agri needs.



COMBi-RT

[combilift.com](http://combilift.com)

DESCRIPTION	Kubota 44 kW	Kubota 74 kW / 99 HP	
Capacity	1500 kg @ 1200 mm	1600 kg @ 1200 mm	3500 lbs @ 48"
Unladen Weight	4450 kg	4650 kg	10,250 lbs
Ground Speed	14 km/h	18 km/h	11 mph
Gradeability	40%		
Kubota Water Cooled Diesel Engine	44 kW	74 kW	99 HP
Overall Width	1800 mm	2000 mm	78¾"
Electrics	12 Volt		
Triplex Mast Lift Height	3150mm		124"
Pivot Fork Section	50 mm x 100 mm x 1830mm		2" x 4" x 72"
Fork Rotation	-	30° each way	
Pneumatic Tractor Grip Tyres	ø 910 mm width 290 mm		ø 36" width 11½"
Fuel Tank Capacity	85 litres		22 Gallons
Hydraulic Tank Capacity	75 litres		20 Gallons

### Features:

- 3 wheel manoeuvrability
- Hydrostatic all wheel drive
- Large tractor grip tyres
- Deep suspension seat
- Back up alarm
- 150 mm / 6" mast side shift
- Pivot Forks

### Benefits:

- Small turning radius
- Reduced maintenance costs
- No mechanical brakes to adjust or replace
- Large ground clearance
- Diff-lock
- Offset driving position gives excellent visibility
- Ergonomically designed cabin for operator comfort

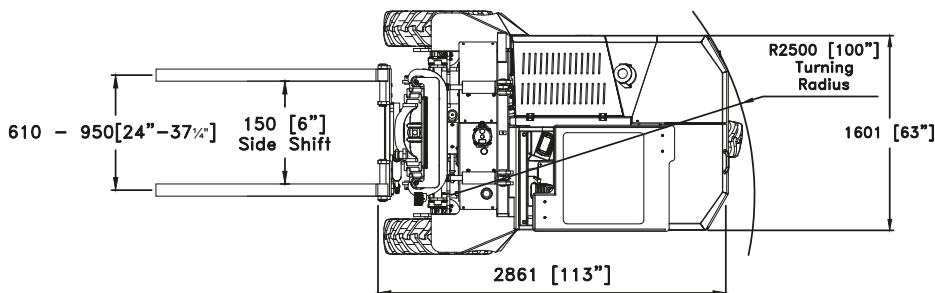
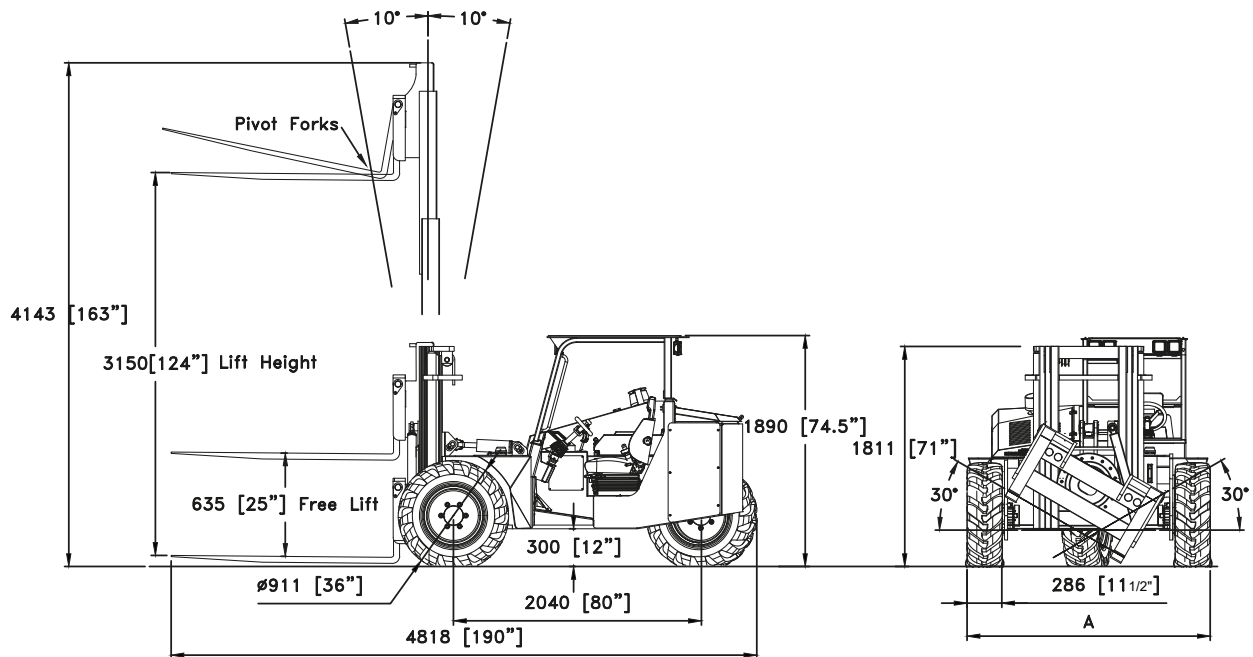

Wir sind für Sie da.

suffel

Suffel Fördertechnik GmbH & Co. KG  
 Wailandtstraße 11 | 63741 Aschaffenburg  
 Telefon 06021 861-400 | industriemaschinen@suffel.com

Aschaffenburg | Mannheim | Schweinfurt | Wiesbaden  
[www.suffel.com](http://www.suffel.com)

Combilift has a policy of continuous product development and reserves the right to alter specifications without prior notice. Specifications and/or dimensions may vary from those illustrated in some countries.

COMBi-RT

combilift.com